

Smart Wi-Fi thermostat terneo bx is designed for remote control of underfloor heating. Its intelligent features allow you to save up to 50 % by maintaining a comfortable temperature only when needed.

Thermostat terneo bx is suitable for controlling underfloor heating based on:

- Heating cable, heating mats, and infrared film;
- Water pipes. The water floor heating is controlled by a thermo-electric servo with an operating voltage of 230 V. The servo can be normally closed or normally open. When connecting a normally open actuator to the terneo, activate the Normally Closed (NC) function in the terneo Mobile App;
- Electric convectors, infrared panels. Heating control is carried out by placing the floor temperature sensor in the air.

When power is lost, all thermostat settings and heating schedule are stored in the thermostat's non-volatile memory, and the clock will continue to operate from the internal power supply for three days.

Scan to access the full web version of the manual

The web version is an interactive, more convenient, and enhanced format of this manual. It also includes additional sections: Button-based settings and Possible issues.



IN THE BOX

Thermostat	1 piece
Temperature sensor with connected wire	1 piece
Installation and operating Manual	1 piece
The packing box	1 piece

TECHNICAL DATA

Adjustment range	5...45 °C	
Maximum load current (for category AC-1)	32 A (max 40 A for 10 min)	
Maximum power load (for category AC-1)	7 000 VA	
Supply voltage	230 V ±10 %	
Temperature sensor (in set)	NTC thermo-resistor 10 kOhm at 25 °C (R10)	
Length of the sensor connected cable	4 m	
Maximum extension length of the temperature sensor	20 m	
Types of the supported sensors:	analog	NTC 4.7, 6.8, 10, 12, 15, 33, 47 kOhm at 25 °C
	digital	D18
The number of operating cycles under load	100 000 cycles	
The number of operating cycles without load	1 000 000 cycles	
Temperature hysteresis by floor	0,1...10 °C, step 0,1 °C	
Wireless networking standard	802,11 b/g/n	
One of the ports is used	tcp 9000, 9010, 9020, 9030	
Minimum speed of Internet connection	128 kb/s	
Operating frequency range	2400–2483,5 MHz	
Minimal Internet traffic	30 MB/ms	
Measured temperature range	–28...+115 °C	
Cross section of connection wires	not more than 16 mm ²	
Weight in the complete set	0,3 kg ±10 %	
Overall dimensions (w·h·d)	53 x 85 x 66 mm	

INSTALLATION

The thermostat is designed for indoor installation. The ingress risk of moisture or liquid into the place of installation must be minimized. The ambient temperature during installation must be between –5...+45 °C. The installation height of the thermostat should be in the range 0,4...1,7 m above the floor level.

The temperature controller should be mounted in a special cabinet, which allows accessible installation and operation. The cabinet must be equipped with a standard 35 mm mounting rail (DIN-rail). The temperature controller has width of three standard 18 mm modules.

In order to protect from short circuits and excess power events appearance in the load circuit, it is necessary to install an automatic circuit breaker (CB), which should be installed in the live wire break, as shown on wiring diagram 1.

In order to protect a person from electric shock, a residual current device (RCD) should be installed. The load should be grounded (connected to the protective conductor) for proper operation of the RCD or, if the power supply is two wire, a protective grounding (i.e. load to neutral to the RCD) should be made.

To install the temperature controller you should:

- fix the temperature controller on the DIN-rail;
- supply power, load and sensor wires;
- make a connection according to this manual.

The terminals of the temperature controller are designed for a wire with a cross section not exceeding 16 mm². It is desirable to use a soft copper wire to reduce the mechanical loads on the terminals. The use of aluminum is not desirable. Strip the ends of wires 10 ±0,5 mm. If the stripped end is longer, it may cause a short circuit and, if shorter, can cause an unreliable connection. Use cable lugs. Loosen the terminal screws and insert the stripped end of the wire into the terminal. Tighten the power terminal with moment of 2,4 N·m and sensor terminal — 0,5 N·m. Poor tightening can lead to poor contact and overheating of terminals and wires, and excessive tightening — to damage of terminals and wires. The wires are tightened in the power terminals with a screwdriver with a bit width of not more than 6 mm, and in the terminals for the sensor — of not more than 3 mm. A screwdriver with a bit width of more than 6 mm for power terminals (more than 3 mm for sensor terminals) can cause mechanical damage to the terminals. This may cause to the loss of the warranty.

If necessary the sensor connecting wires may be shortened and extended (for not more than 20 m).

It is necessary for the temperature controller to switch the current to no more than 2/3 of the maximum

current specified in the specification. If the current exceeds this value, the load must be connected through a contactor (magnetic actuator, power relay), which is optimized for this current (wiring diagram 2).

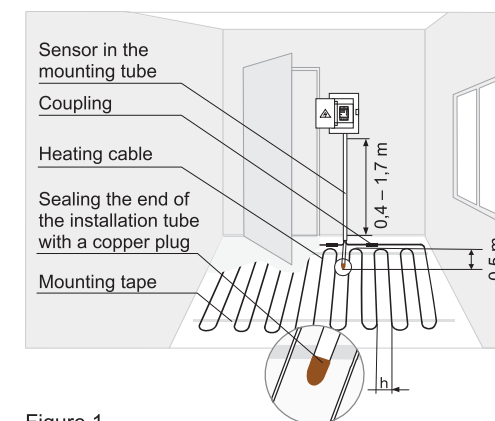

Figure 1. Installation the thermostat and underfloor heating

WARRANTY TERMS

The warranty for devices is valid for 36 months from the date of sale, provided that the instructions are followed. The warranty period for products without a warranty certificate is counted from the date of production.

If your device is not working properly, we recommend that you first read the section "Possible problems". If you cannot find an answer, contact Service center, in most cases, these actions resolve all issues.

If you continue to have issues with the device, please, contact the General distributor in your area or the store where you purchased the device. If your device is defective due to our fault, we will repair or replace it under warranty within 14 business days.

Please check the full text of the warranty and the data you need to send to your Service center on the website <https://www.ds-electronics.company>



SERVICE CENTER CONTACT
+38 (091) 481-91-81
Viber WhatsApp Telegram
support@dse.com.ua

WARRANTY CARD

serial №:	date of sale:
a seller, a seal:	
place of a seal	
an owner contact for a service center:	

ELECTRICAL CONNECTION DIAGRAM

The thermostat must be mounted and connected only after the load has been installed and tested! Read this document in full before starting installation and operation of the thermostat. This will help you avoid possible hazards, mistakes, and misunderstandings.

The thermostat supports operation with two types of sensors: analog (R10) and digital (D18). The analog sensor is included in the thermostat package and is connected to terminals 1 and 2.

To connect the digital sensor, connect the blue wire to terminal 2, the white wire to terminal 1, and be sure to change the Sensor Type in the menu to d18.

The supply voltage (230 V \pm 10 %, 50 Hz) is applied to terminals 3 and 4. The phase (L) is detected by the indicator and must be connected to terminal 4, and neutral (N) — to terminal 3.

The load connection wires are connected to terminal 5 and to the neutral terminal (not included in the package).

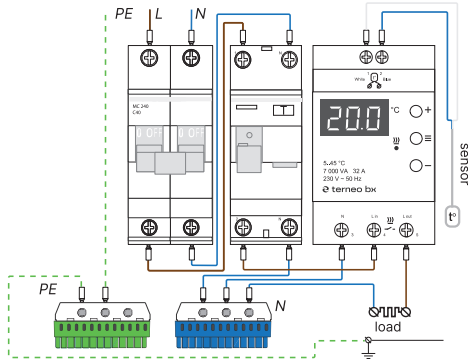

Diagram 1. Connection diagram of the thermostat, circuit breaker and RCD

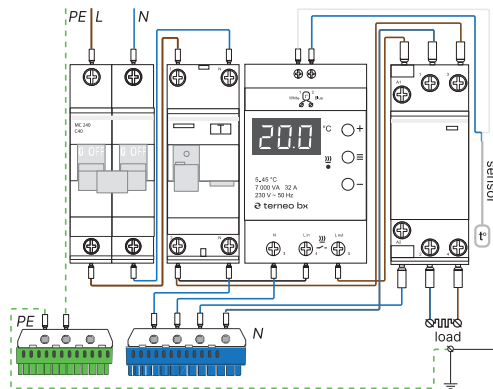

Diagram 2. Connection through a contactor (magnetic starter)

BINDING TO THE APP

When binding, be sure to select 2.4G. During operation, the router always creates two networks: 2.4G and 5G. The thermostat terneo bx does not work with 5G Wi-Fi networks.

- It is not recommended to connect the thermostat to a Wi-Fi network that uses Multi WAN technology.



Status of the indicator on the thermostat

● lights	connection to the server is available
○ does not light	no Wi-Fi connection or it is turned off
(●) flashing 1 time / 0,5 sec	mode Access Point (AP)
(●) flashing 1 time / 3 sec	Client mode "CLI" Wi-Fi is available, but there is no connection to the server

Connect the terneo bx to iOS or Android

For your convenience, we have prepared video instructions — How to connect the terneo Smart Wi-Fi thermostat to the mobile application.

for iOS



for Android



- Download the terneo app from Google Play for Android or from the App Store for iOS.
- Register or log in using your Telegram, Apple ID, or Google account.
- Upon the first power-up, the thermostat will enter the "AP" mode for the first 10 minutes. After that, set the "AP mode" independently:
 - click "≡" until "APC" is displayed
 - by means of "+" and "-" to select "AP"
- Go to the app and press "+" → "Device" or "≡" → "Add" → "Device".

Complete the setup for iOS

- Enter the name and password of your Wi-Fi network, then press "Next"
- Go to Wi-Fi Settings on your iPhone. Connect to the Wi-Fi network created by the thermostat; its name will be in the format — terneo bx_A68FDB. Enter the password DSEXXXXXX, where XXXXXX represents the last six characters of the network name (for example: DSEA68FDB).

Complete the setup for Android

- Select the Wi-Fi network created by the thermostat, for example, terneo bx_A68FDB.
- Then follow the prompts in the app. If there is an internet connection, the thermostat will be added to the main screen of the app and registered in the servers.

Next, return to the application and follow the prompts. If you have an internet connection, the thermostat will be added to the main screen of the application and registered in the server.

Connection through the desktop application www.my.terneo.ua

- From the thermostat buttons, go to the "Wi-Fi mode" menu section by pressing the menu button until "APC" appears on the screen. Make sure that it is in the "AP" mode. If "CLI" (client) is displayed on the screen, use the "+" or "-" buttons to select the "AP" mode.
- On your computer, go to Wi-Fi settings and connect to the Wi-Fi network created by the thermostat. Its name will be in the format terneo bx_A68FDB. If a password is required for the connection, enter DSEXXXXXX, where XXXXXX represents the last six characters in the network name (for example: DSEA68FDB).

The Android operating system may prompt you to confirm the connection to a Wi-Fi network that has no internet access. To proceed with the connection, press "Do not disconnect".

- Open the browser and enter 192.168.0.1 in the address bar.
- On the browser page of the thermostat interface, select your Wi-Fi network and enter its password. Click "Connect".
- Please wait for a minute until the thermostat connects to your Wi-Fi network, and the indicator on the thermostat lights up blue.
- Go to the Wi-Fi settings on your phone or computer and make sure you are already connected to your home Wi-Fi network.
- Go to my.terneo.ua and register using your Telegram, Apple ID, or Google account.
- To add a thermostat, press "+ Add" → "Device" → set a name, for example, "Bedroom" → enter the PIN-code from the thermostat screen → press "Next" to add the device.



If you don't see the PIN-code on the thermostat screen, press the "≡" 3 times until "Pin" appears on the screen. Then, press "+" or "-" to request the PIN-code.

Possible issues:

- If instead of the PIN-code, the thermostat displays "iP", it indicates a lack of connection to the server. Check the internet connection on the router to which the thermostat is connected.
- If you cannot find the "Pin" and "iP" in the menu, it means there is no Wi-Fi connection. Repeat the connection process through the desktop application starting from step 1.

How the thermostat works in the presence of the Internet

The thermostat is constantly synchronized with the server, executing its commands, receiving the latest settings, and sending telemetry about its status. If you disable remote control of the thermostat, the server can only be used to accumulate statistics. For proper operation of statistics and heating schedule, after connecting to the server, please specify your time zone. Afterwards, the thermostat will automatically update the date and time via the Internet.

How the thermostat works in the absence of the Internet

The thermostat continues to operate according to the set settings. During this time, you can control the thermostat using the thermostat's buttons or the offline mode in the terneo app. Please note that instead of a fixed internet connection, you can use mobile internet. For this, you will need a separate device (for example, a smartphone) that will act as a Wi-Fi hotspot. After restoring the Internet connection, all settings will be synchronized.

SAFETY INSTRUCTIONS

To avoid injury and damage to the thermostat, carefully read and understand these instructions for yourself.

The installation of the thermostat should be carried out by a qualified electrician.

Do not connect 230 V mains voltage instead of the sensor (this will damage the thermostat).

Before starting the installation (disassembly) and connection (disconnection) of the thermostat, disconnect the power supply and follow the "Rules of an arrangement of Electric Installations".

Do not immerse the sensor with its connecting wire in liquid environment.

Do not connect the thermostat to the power supply in a disassembled state.

Prevent liquid or moisture from coming into contact with the thermostat.

Do not expose the device to extreme temperatures (above 40 °C or below -5 °C) and high humidity.

Do not clean the thermostat using chemicals such as benzene and solvents.

Do not store or use the thermostat in dusty environments.

Do not attempt to disassemble or repair the thermostat yourself.

Do not exceed the maximum current and power limits.

Use surge protectors to protect against overvoltage caused by lightning discharges.

Keep children away from playing with a functioning device as it is dangerous.

version: F26_2511

RoHS Directive 2011/65/EU
Low Voltage Directive 2014/35/EU, EMC Directive 2014/30/EU



Manufacturer and vendor: DS ELECTRONICS LTD
Ukraine, 04136, Kyiv region, Kyiv, 1-3 Pivnichno-Syretska str.
Sales Department: +38 (091) 481-91-81, support@dse.com.ua
www.terneo.com